

Features

- Fully assembled Pick & Place unit with all mounting components — ready to install, plumb and run.
- Components come with our stopscrew system for accurate stroke adjustment and optional sensing capabilities. (see page 143)
- Made from our standard proven precision components including our Tuff-Series line of linear actuators.
- We can supply a gripper mounting plate or make a custom one for any end-effector.

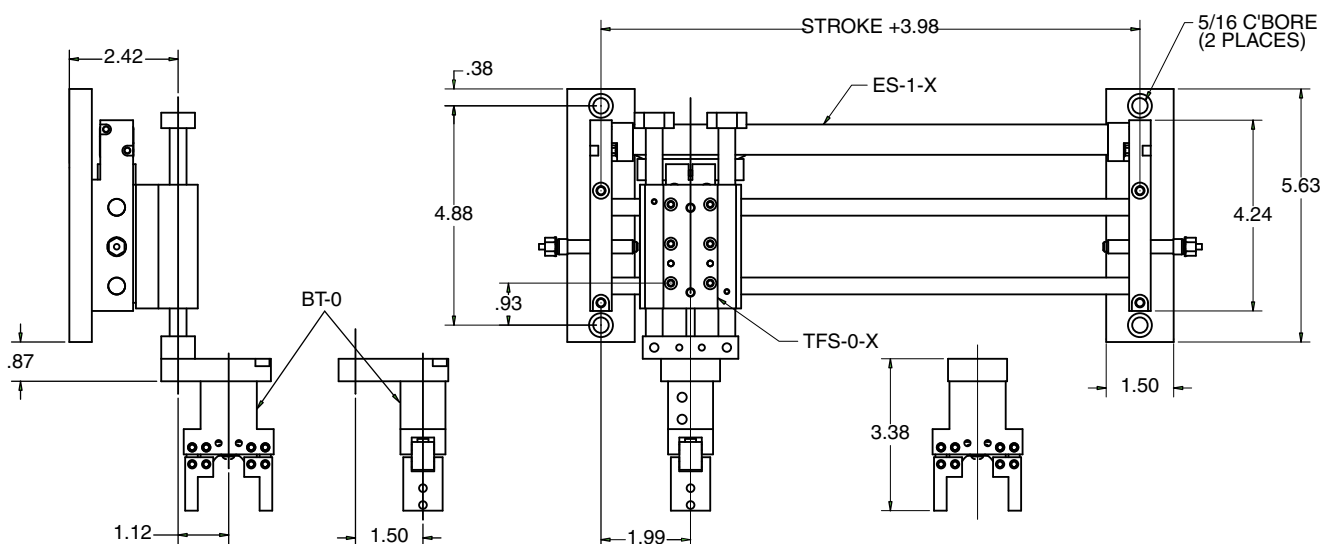
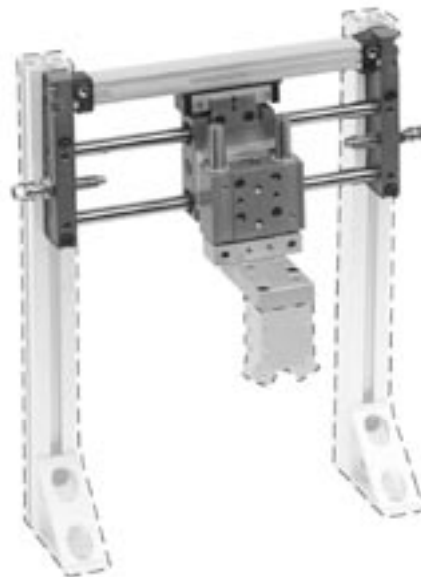

P

Ordering

The CMU-ESTF10 includes a ES-1, TFS-0, adapter plate, and optional gripper mounting plate and can be ordered with the following number:

Technical Data

ES -1	= 3/8" BORE
TFS -0	= 1/2" BORE
AIR CONNECTION	= 10-32
AIR PRESSURE	= 60 - 110 PSI
RECOMMENDED LOAD	= 3 lbs.

CMU-ESTF10 - [] - [] - []

ES-1 SIZE
STROKE IN INCHES

TFS-0 SIZE
05 (0.5" STROKE)
10 (1.0" STROKE)
15 (1.5" STROKE)

GRIPPER ADAPTER
N - No adapter
0 - Adapter for BT-0 series gripper